



**BACK TO BASICS**

# **From Raw Materials to Performance**

Revisiting the fundamentals of Cement Manufacturing

➤ Dr. Grizelda du Toit

07 May 2026



# Content

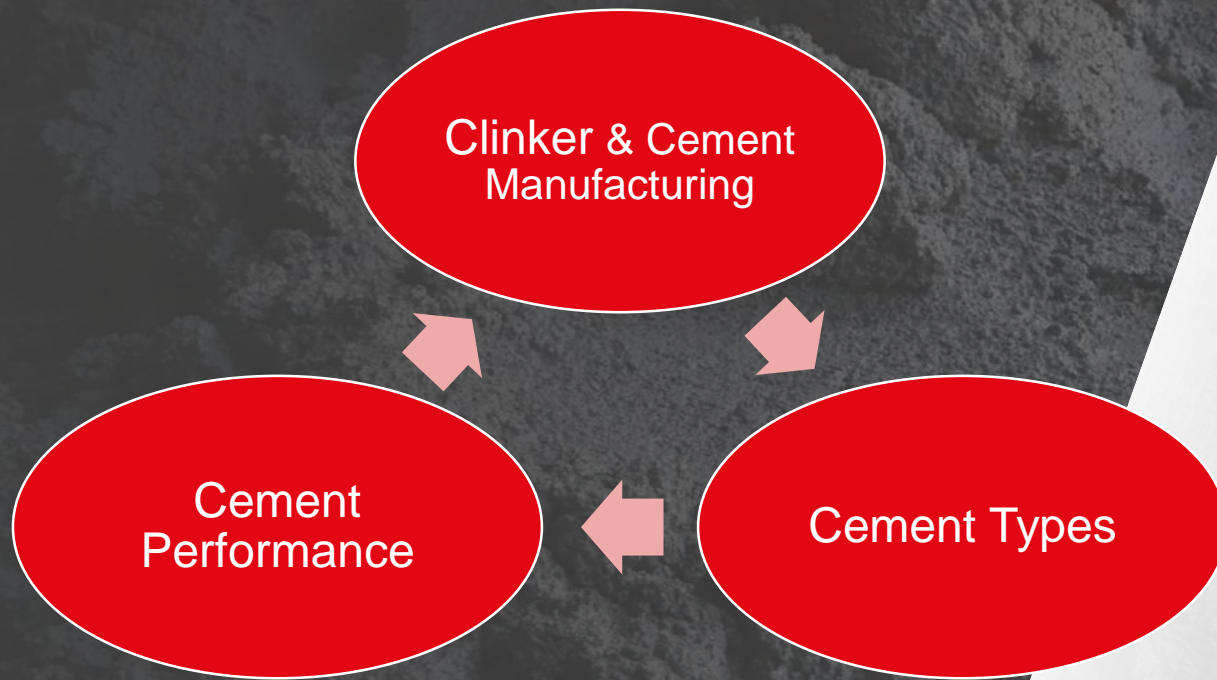

# SO SIMPLE, ANYONE CAN DO IT.

1. ROCKS  
(BORING)



2. GRIND THEM  
(VERY BORING)

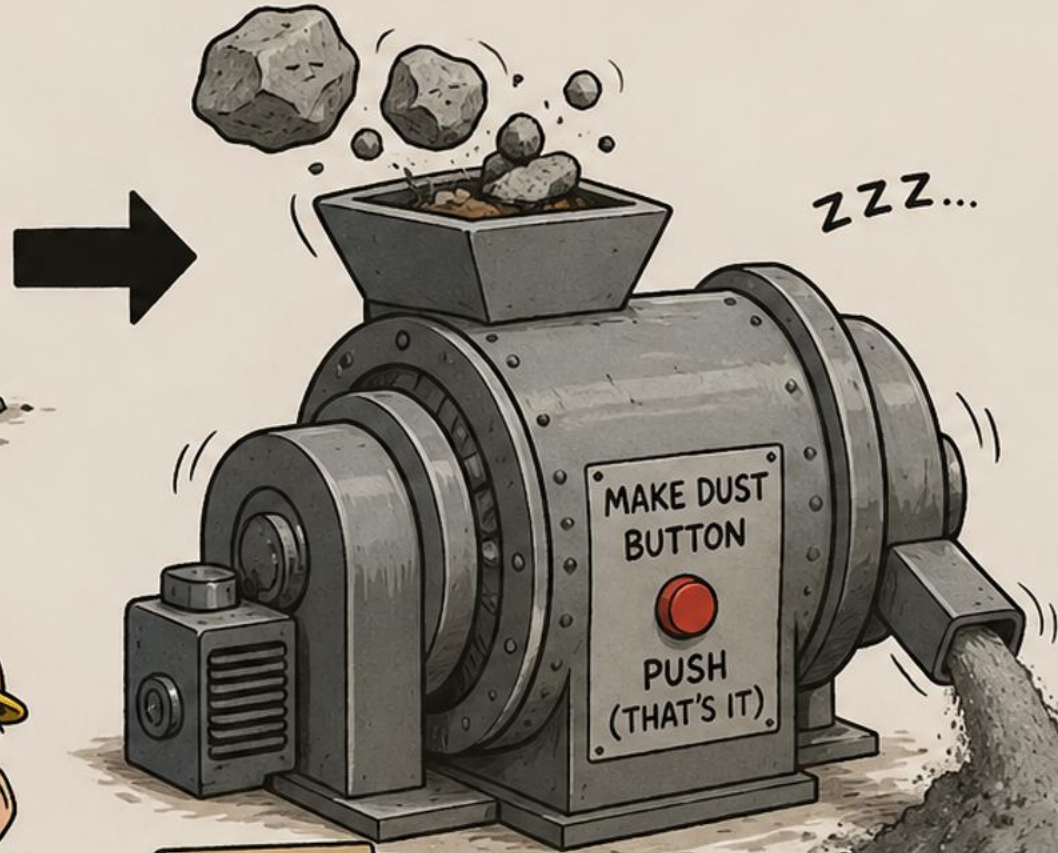

3. GREY POWDER  
(CEMENT)

WOW.  
SO EXCITING.

ZZZ...

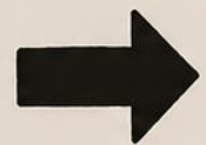

NO CHEMISTRY.  
NO EQUATIONS.  
NO SCIENCE.  
JUST... GRIND ROCK.  
MAKE GREY.  
THAT'S THE WHOLE SECRET.



CEMENT  
MAKING  
DEGREE?  
**LOL**  
DON'T NEED IT

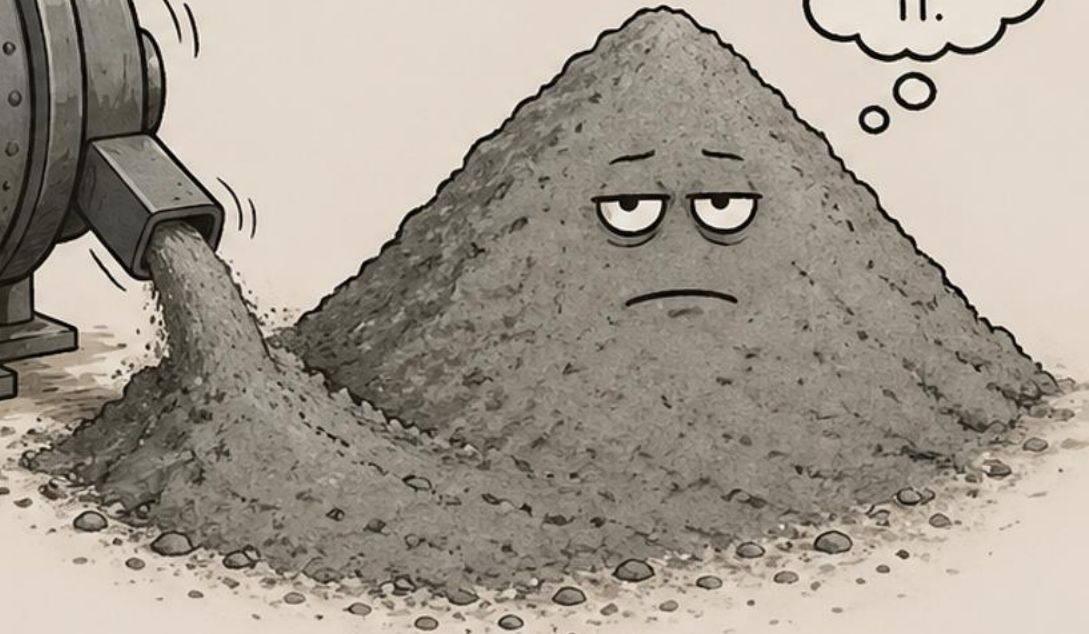



LIMESTONE CLAY / SHALE SILICA IRON ORE ALUMINA GYPSUM



RAW MATERIAL PREPARATION



PROPORTIONING



GRINDING & DRYING



PARTICLE SIZE DISTRIBUTION

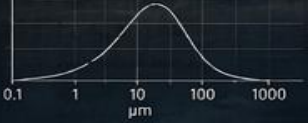

ADDITIVES

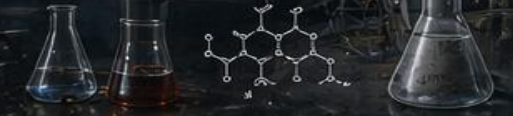

CEMENT GRINDING



HYDRATION (Simplified)

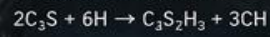

KILN OPERATION

~1450°C  
Residence time  
20-60 min



CLINKER MINERAL CHEMISTRY

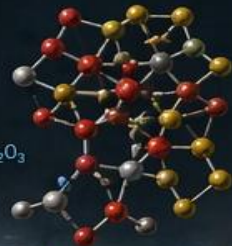
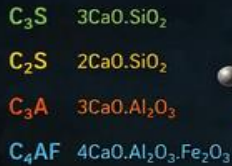

CLINKER MICROSTRUCTURE

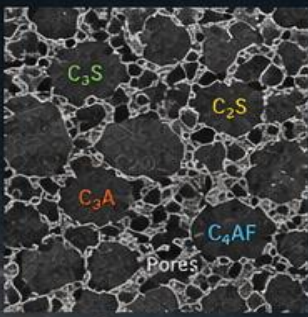

BURNING ZONE  
~1400-1450°C



COOLING

Rapid cooling stabilizes phases



PROCESS PARAMETERS

- Temperature
- Pressure
- Residence time
- Feed chemistry
- Fuel rate
- Air flow
- Kiln speed
- Feed moisture

GASEOUS EMISSIONS  
 $CO_2$   $H_2O$   $NO_x$   $SO_x$



ALTERNATIVE FUELS

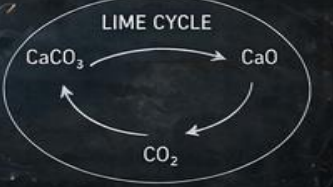

GYPSUM



QUALITY & PERFORMANCE

- STRENGTH (weight icon)
- DURABILITY (shield icon)
- WORKABILITY (funnel icon)
- HEAT OF HYDRATION (thermometer icon)



CONTROL & OPTIMIZATION

Data Models  
Advanced Control  
AI / Machine Learning





# CEMENT MANUFACTURING PROCESS

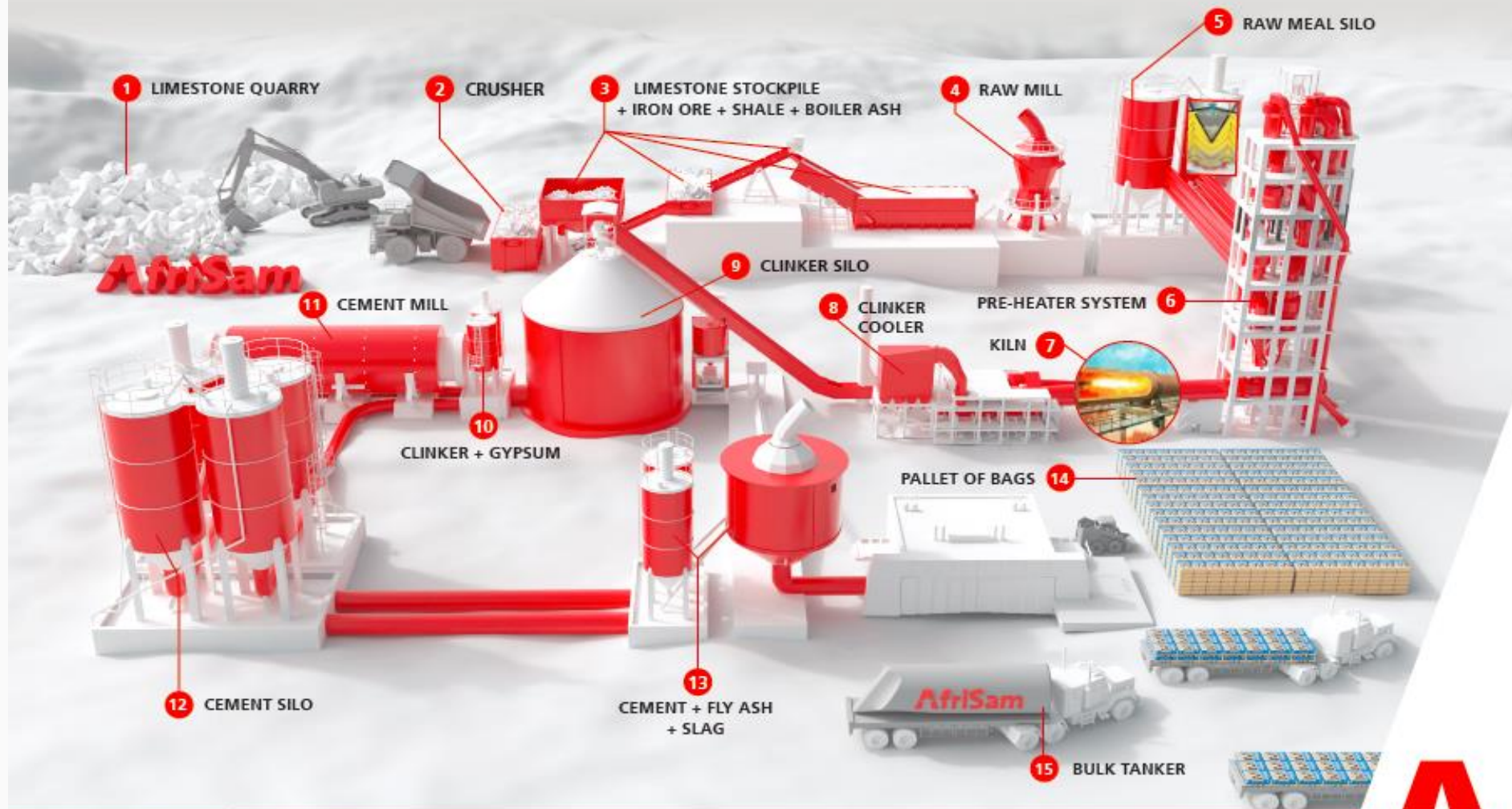

[www.afrisam.com](http://www.afrisam.com)

Creating Concrete Possibilities





# The Quarry

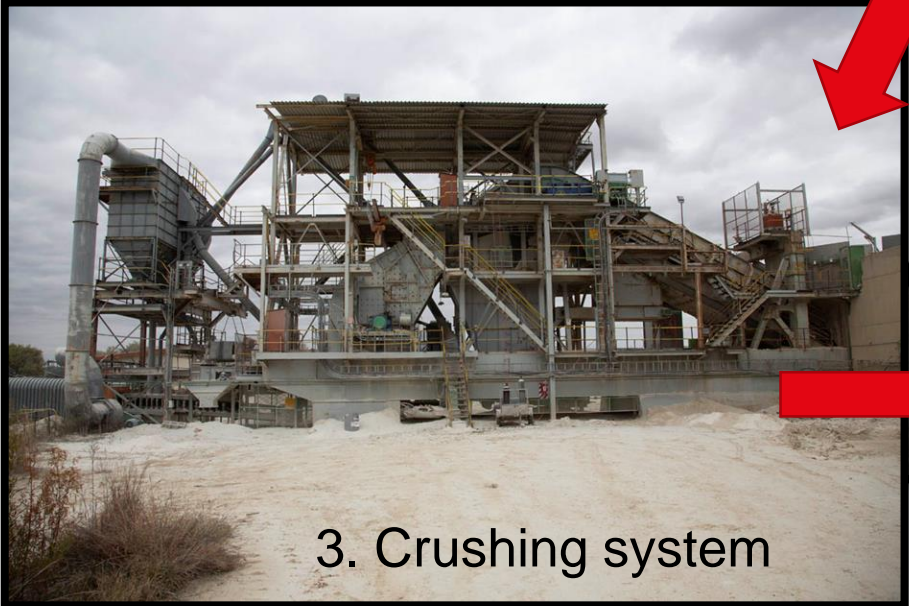

CONFIDENTIAL





# The Quarry

Varying limestone chemistry



Raw meal variability



Variable clinker mineralogy



Setting and strength  
variability





# Raw Materials

- Source of calcium : Limestone  
 $\text{CaCO}_3 / \text{SiO}_2 \rightarrow 91\%$
- Source of alkalis and alumina e.g. Shale  
 $\text{Al}_2\text{O}_3 / \text{Alkali's} \rightarrow 4\%$
- Source of alumina e.g. Boiler ash  
 $\text{Al}_2\text{O}_3 \rightarrow 4\%$
- Source of iron e.g Iron ore  
 $\text{Fe}_2\text{O}_3 \rightarrow 1\%$

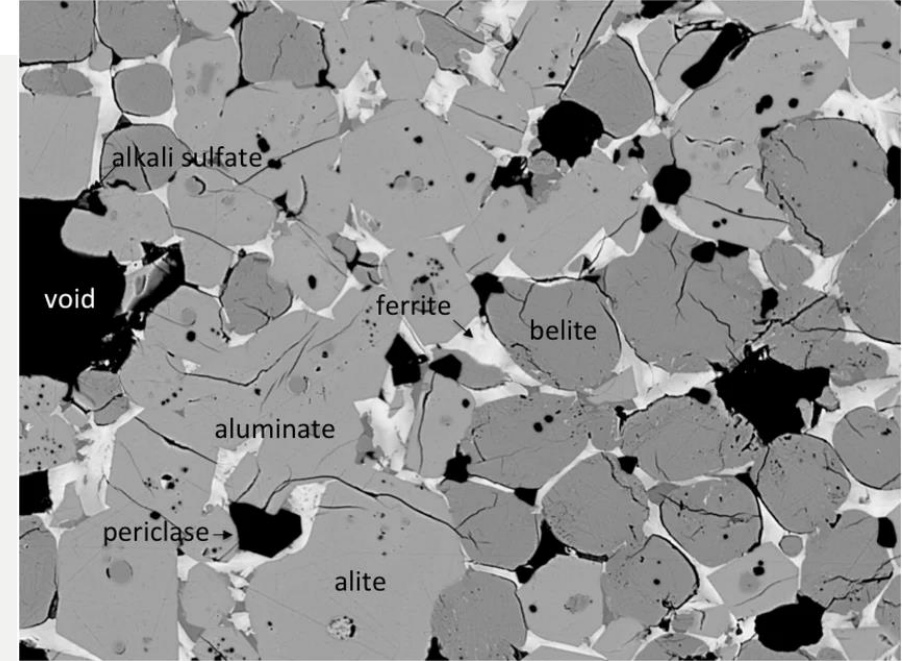

**$\text{C}_3\text{S}$  = Tricalcium Silicate (Alite)**

**$\text{C}_2\text{S}$  = Dicalcium Silicate (Belite)**

**$\text{C}_3\text{A}$  = Tricalcium Aluminate**

**$\text{C}_4\text{AF}$  = Tetracalcium Aluminoferrite**

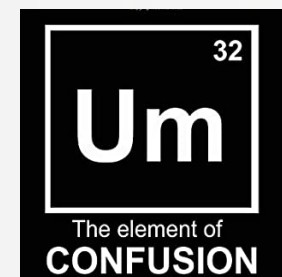

# Raw Meal Preparation – Stockpiling, Milling & Storage

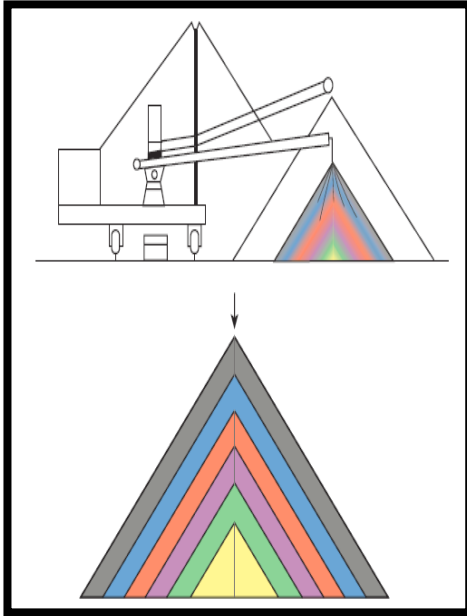

Circular Stacking  
(Chevron method)

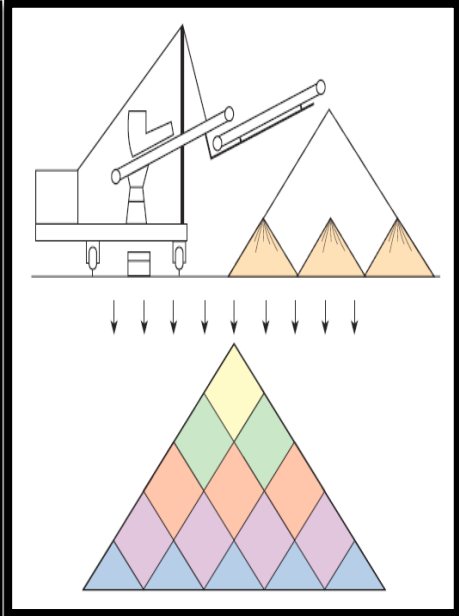
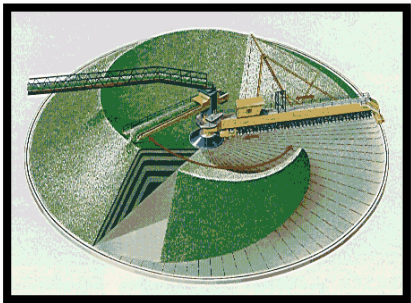

Layer-type stockpiling  
(Windrow method)

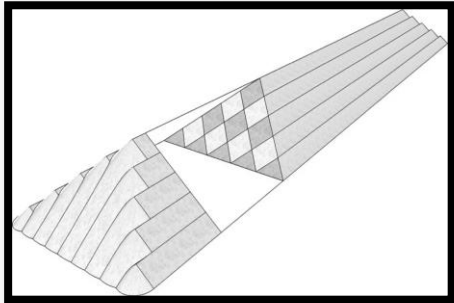

Vertical Roller Mill (VRM)

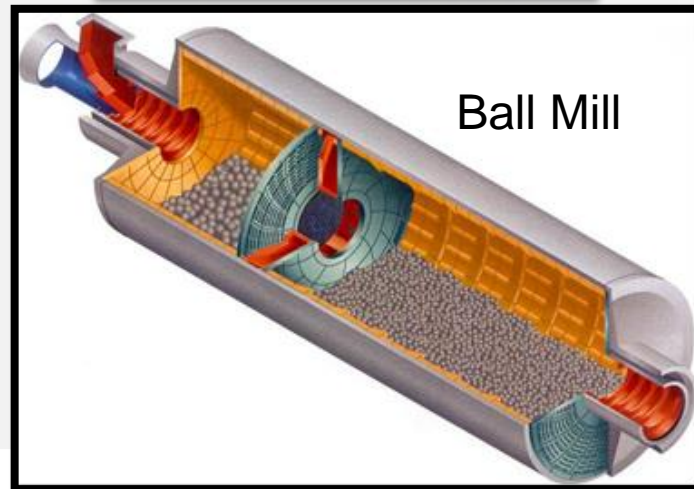
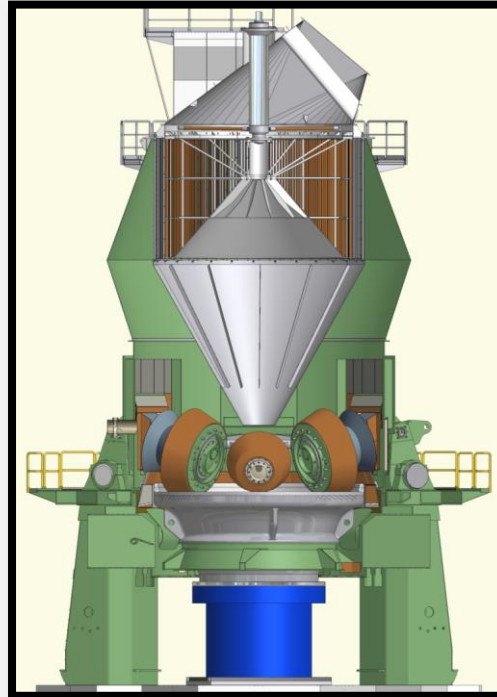

Ball Mill

Homogenizing Silo





# Raw Meal Preparation – Stockpiling, Milling & Storage

Vertical Roller Mill (VRM)



Ball Mill





# Raw Meal Preparation – Stockpiling, Milling & Storage

Variable raw meal chemistry  
and fineness



Unstable kiln temperature profile



Variable clinker mineralogy



Setting, expansion (high F.Cao)  
& strength variability



# Preheater and Kiln System - Clinkering

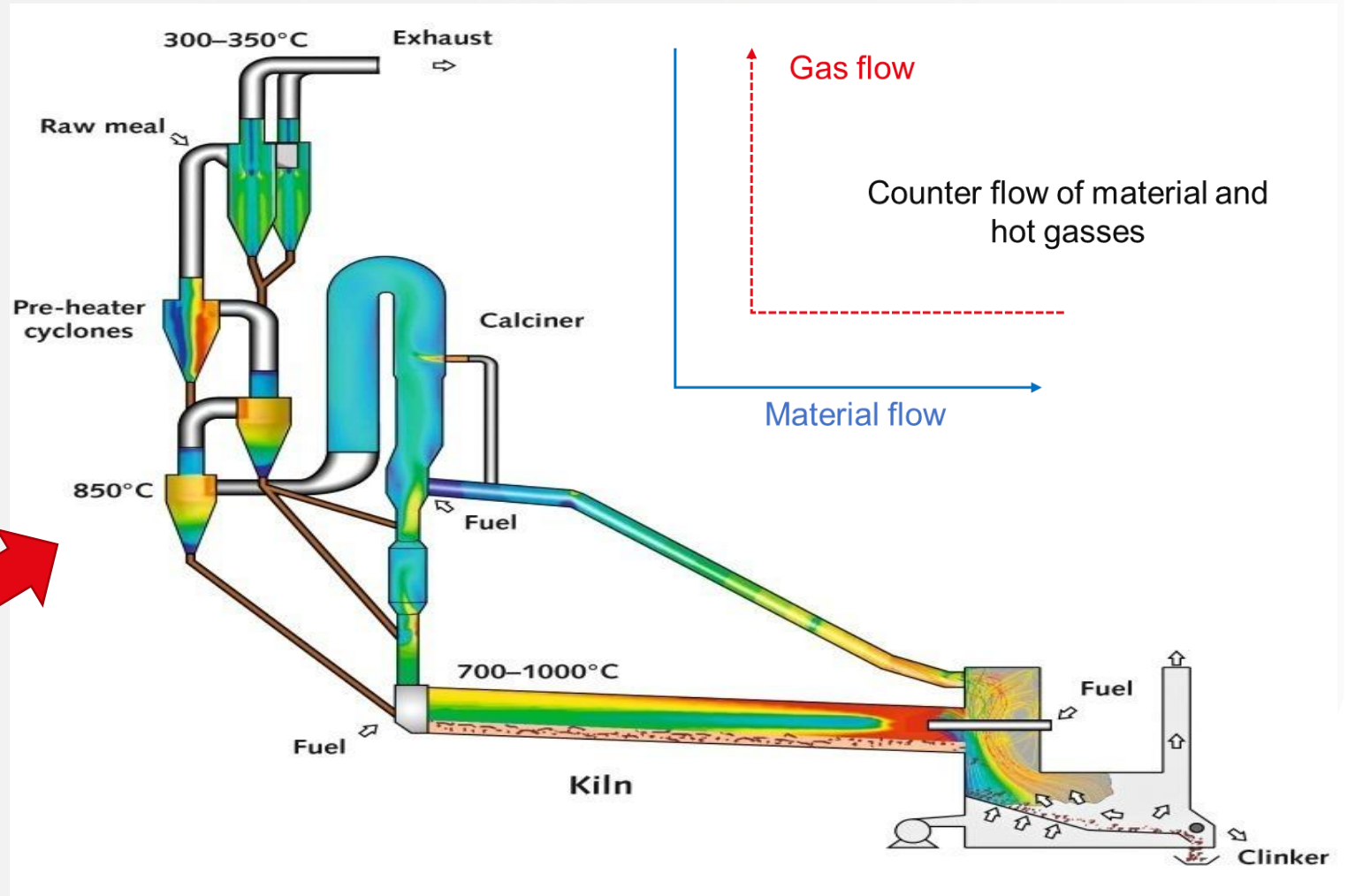
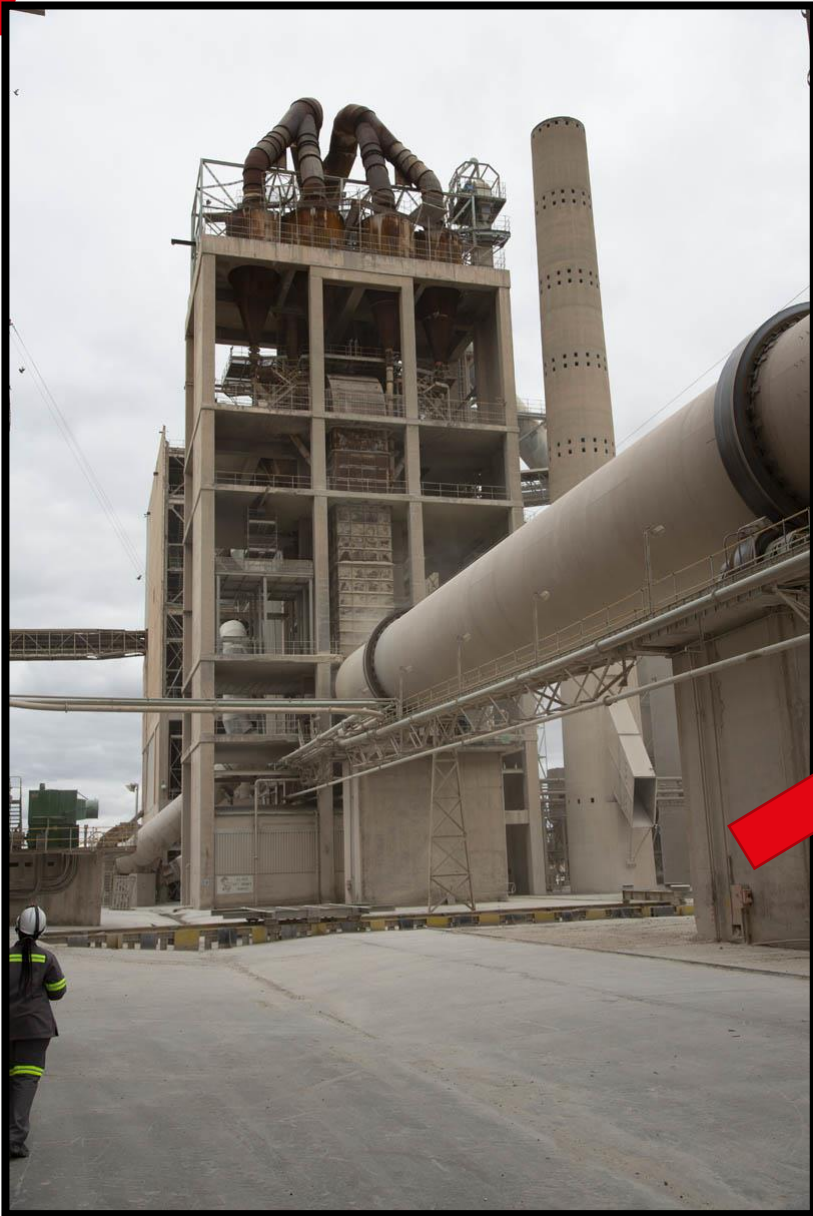



# Preheater and Kiln System - Clinkering

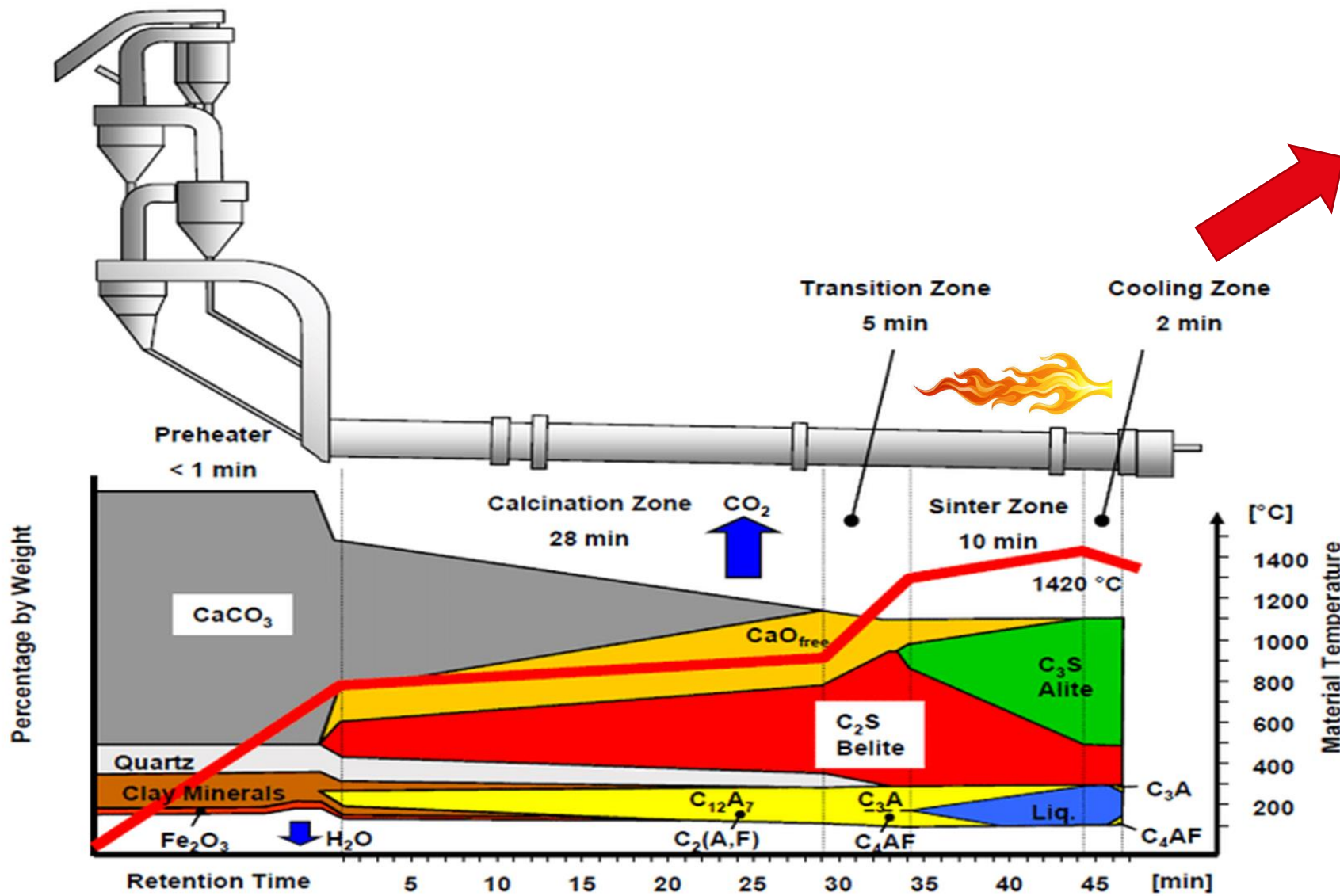

## CO<sub>2</sub> in clinker manufacturing:

De-carbonation of limestone

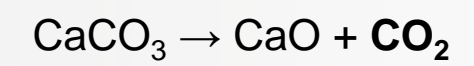

Combustion of Fuel

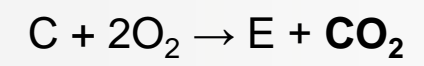



# Preheater and Kiln System - Clinkering

**Thermal instability**

**High alkali / sulfur / chloride build-ups**

**Cooling inefficiency**



**Setting, expansion (high F.Cao) & strength (low C<sub>3</sub>S)**





# Cement Milling

Vertical Roller Mill (VRM)



Ball Mill



Clinker



Gypsum



Grinding aid



Cement





# Cement Milling

**High residues**

**Variable gypsum addition and/or  
insufficient gypsum dehydration**

**Uncontrolled/variable limestone  
addition**



**Setting variability & Low strength**



# Cement Blending / Types of Cement : SANS 50197-1

Main types	Notation of the 27 products (types of common cement)		Composition (percentage by mass <sup>a</sup> )										Minor additional constituents	
			Main constituents											
			Clinker	Blast-furnace slag	Silica fume	Pozzolana		Fly ash		Bumt shale	Limestone			
						natural	natural calcined	siliceous	calcareous		L	LL		
K	S	D <sup>b</sup>	P	Q	V	W	T	L	LL					
CEM I	Portland cement	CEM I	95-100	–	–	–	–	–	–	–	–	–	–	0-5
CEM II	Portland-slag cement	CEM III/A-S	80-94	6-20	–	–	–	–	–	–	–	–	–	0-5
		CEM II/B-S	65-79	21-35	–	–	–	–	–	–	–	–	–	0-5
	Portland-silica fume cement	CEM III/A-D	90-94	–	6-10	–	–	–	–	–	–	–	–	0-5
	Portland-pozzolana cement	CEM III/A-P	80-94	–	–	6-20	–	–	–	–	–	–	–	0-5
		CEM III/B-P	65-79	–	–	21-35	–	–	–	–	–	–	–	0-5
		CEM II/A-Q	80-94	–	–	–	6-20	–	–	–	–	–	–	0-5
		CEM II/B-Q	65-79	–	–	–	21-35	–	–	–	–	–	–	0-5
	Portland-fly ash cement	CEM III/A-V	80-94	–	–	–	–	6-20	–	–	–	–	–	0-5
		CEM II/B-V	65-79	–	–	–	–	21-35	–	–	–	–	–	0-5
		CEM III/A-W	80-94	–	–	–	–	–	6-20	–	–	–	–	0-5
CEM II/B-W		65-79	–	–	–	–	–	21-35	–	–	–	–	0-5	
Portland-bumt shale cement	CEM II/A-T	80-94	–	–	–	–	–	–	6-20	–	–	–	0-5	
	CEM II/B-T	65-79	–	–	–	–	–	–	21-35	–	–	–	0-5	
Portland-limestone cement	CEM III/A-L	80-94	–	–	–	–	–	–	–	6-20	–	–	0-5	
	CEM II/B-L	65-79	–	–	–	–	–	–	–	21-35	–	–	0-5	
	CEM II/A-LL	80-94	–	–	–	–	–	–	–	–	6-20	–	0-5	
Portland-composite cement <sup>c</sup>	CEM III/A-M	80-88	←----- 12-20 -----→									0-5		
	CEM II/B-M	65-79	←----- 21-35 -----→									0-5		
CEM III	Blast furnace cement	CEM III/A	35-64	36-65	–	–	–	–	–	–	–	–	–	0-5
		CEM III/B	20-34	66-80	–	–	–	–	–	–	–	–	–	0-5
		CEM III/C	5-19	81-95	–	–	–	–	–	–	–	–	–	0-5
CEM IV	Pozzolanic cement <sup>c</sup>	CEM IV/A	65-89	–	←----- 11-35 -----→					–	–	–	0-5	
		CEM IV/B	45-64	–	←----- 36-55 -----→					–	–	–	0-5	
CEM V	Composite cement <sup>c</sup>	CEM V/A	40-64	18-30	–	←----- 18-30 -----→		–	–	–	–	–	0-5	
		CEM V/B	20-38	31-49	–	←----- 31-49 -----→		–	–	–	–	–	0-5	

<sup>a</sup> The values in the table refer to the sum of the main and minor additional constituents.

<sup>b</sup> The proportion of silica fume is limited to 10 %.

<sup>c</sup> In Portland-composite cements CEM III/A-M and CEM II/B-M, in pozzolanic cements CEM IV/A and CEM IV/B and in composite cements CEM V/A and CEM V/B the main constituents other than clinker shall be declared by designation of the cement (for examples, see Clause 8).

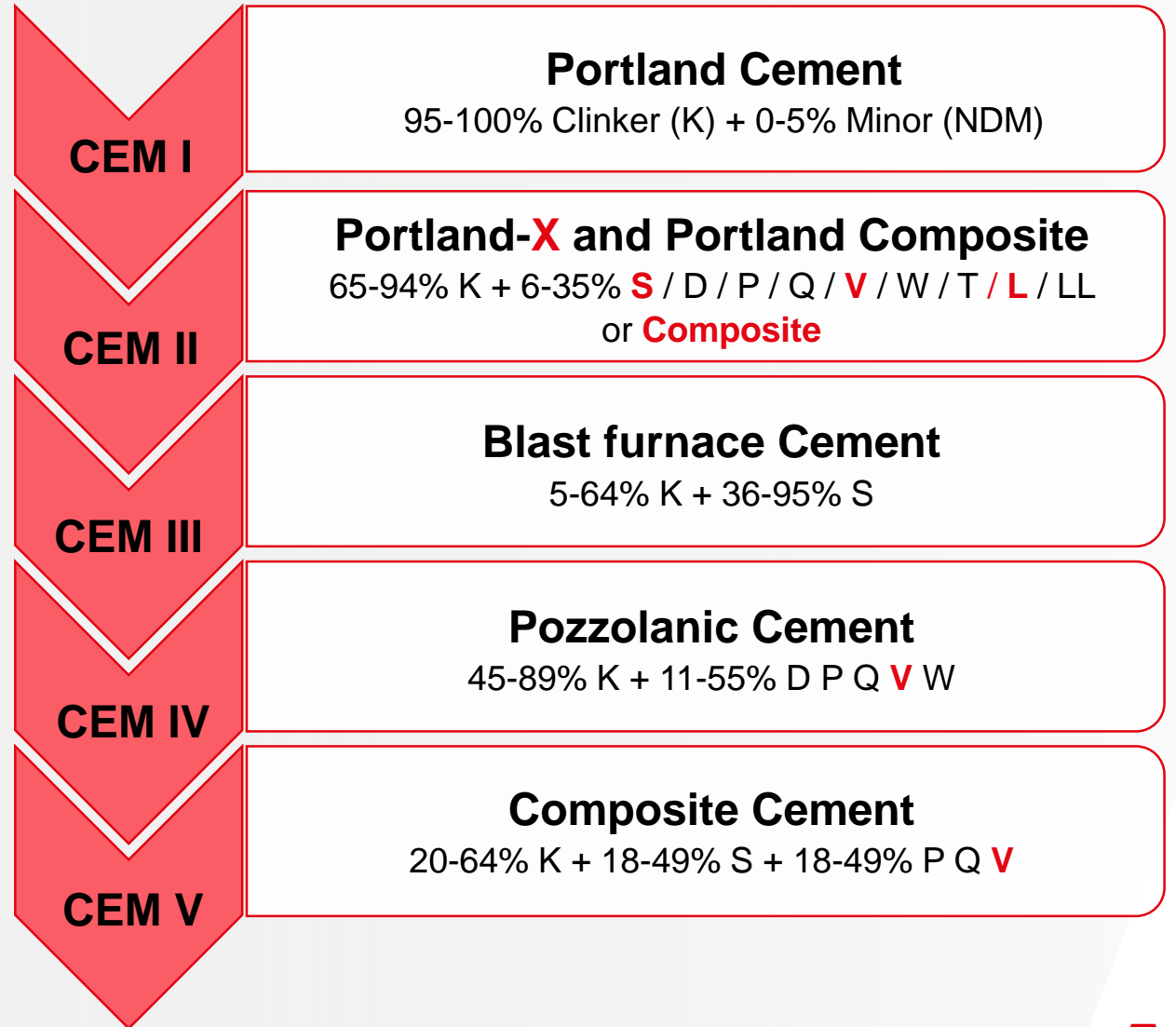



# Cement Blending / Types of Cement : SANS 50197-1

Inconsistent addition of MIC



Setting & strength variability





# Cement Performance – different composition

Strength class	Compressive strength MPa			
	Early strength		Standard strength	
	2 days	7 days	28 days	
32,5 L <sup>a</sup>	-	≥ 12,0	≥ 32,5	≤ 52,5
32,5 N	-	≥ 16,0		
32,5 R	≥ 10,0	-	≥ 42,5	≤ 62,5
42,5 L <sup>a</sup>	-	≥ 16,0		
42,5 N	≥ 10,0	-		
42,5 R	≥ 20,0	-		

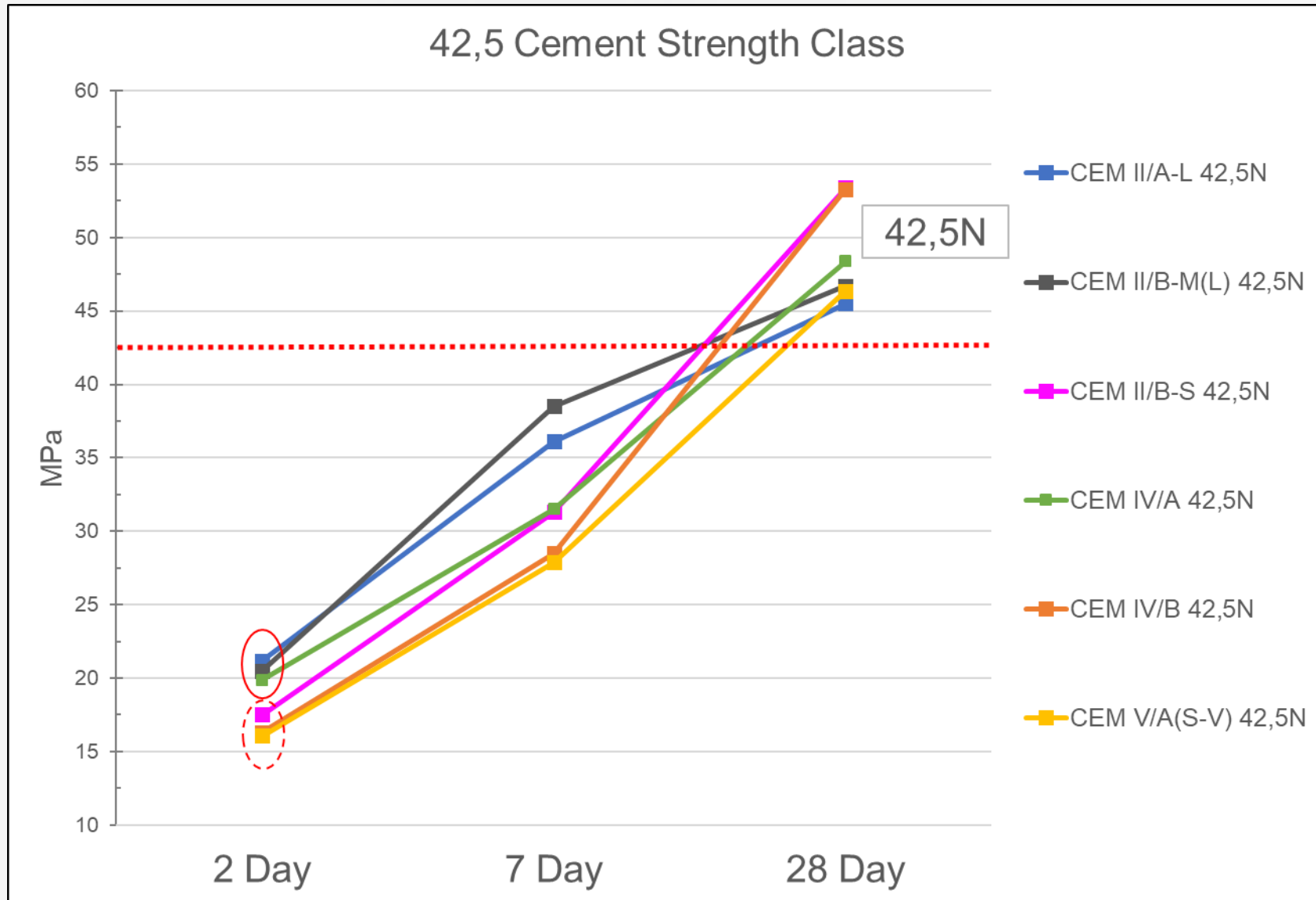



# Cement Performance – different composition

Strength class	Compressive strength MPa			
	Early strength		Standard strength	
	2 days	7 days	28 days	
32,5 L <sup>a</sup>	-	≥ 12,0	≥ 32,5	≤ 52,5
32,5 N	-	≥ 16,0		
32,5 R	≥ 10,0	-		
42,5 L <sup>a</sup>	-	≥ 16,0	≥ 42,5	≤ 62,5
42,5 N	≥ 10,0	-		
42,5 R	≥ 20,0	-		

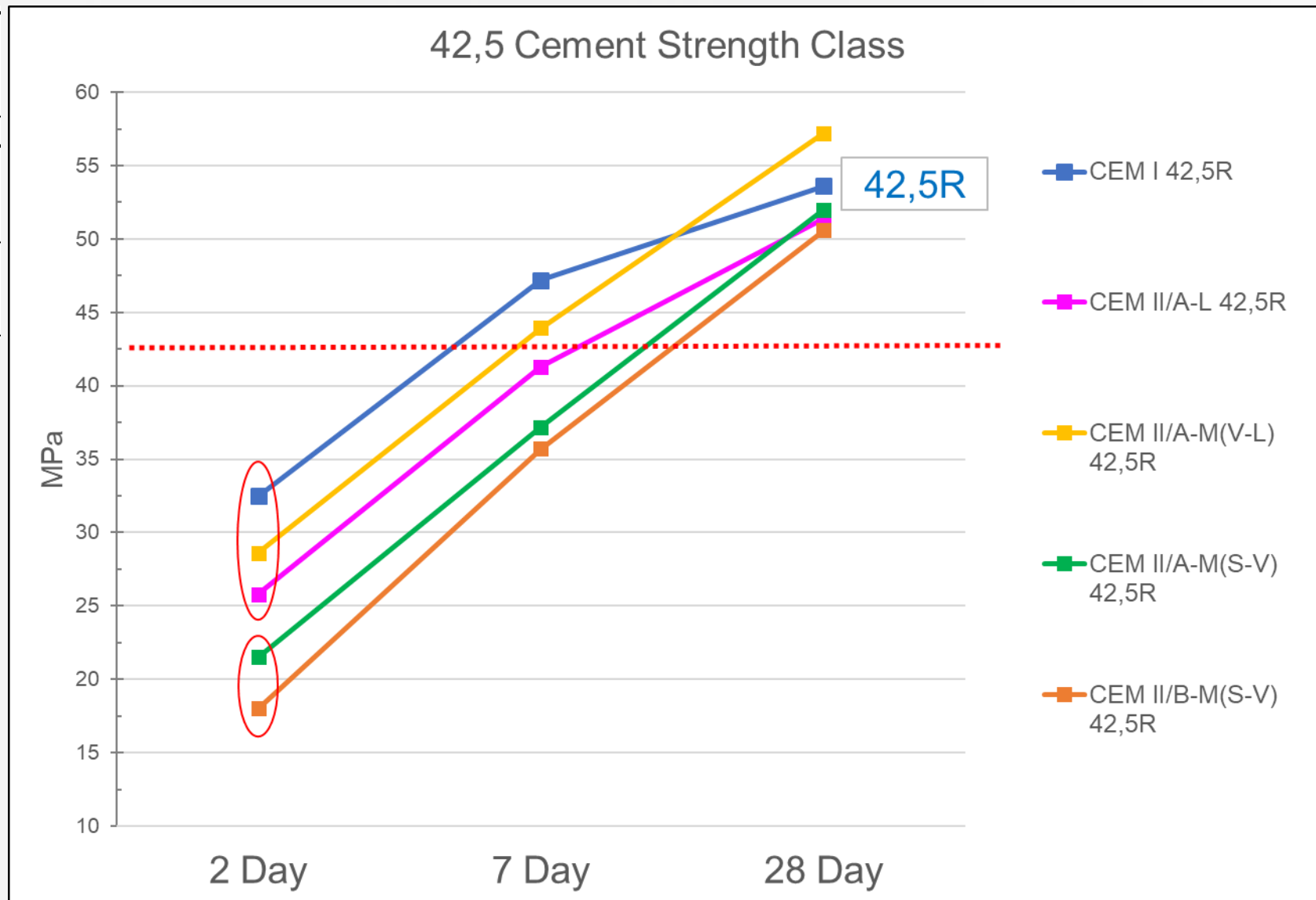



# Cement Performance – different composition

Strength class	Compressive strength MPa			
	Early strength		Standard strength	
	2 days	7 days	28 days	
32,5 L <sup>a</sup>	-	≥ 12,0	≥ 32,5	≤ 52,5
32,5 N	-	≥ 16,0		
32,5 R	≥ 10,0	-		
42,5 L <sup>a</sup>	-	≥ 16,0	≥ 42,5	≤ 62,5
42,5 N	≥ 10,0	-		
42,5 R	≥ 20,0	-		

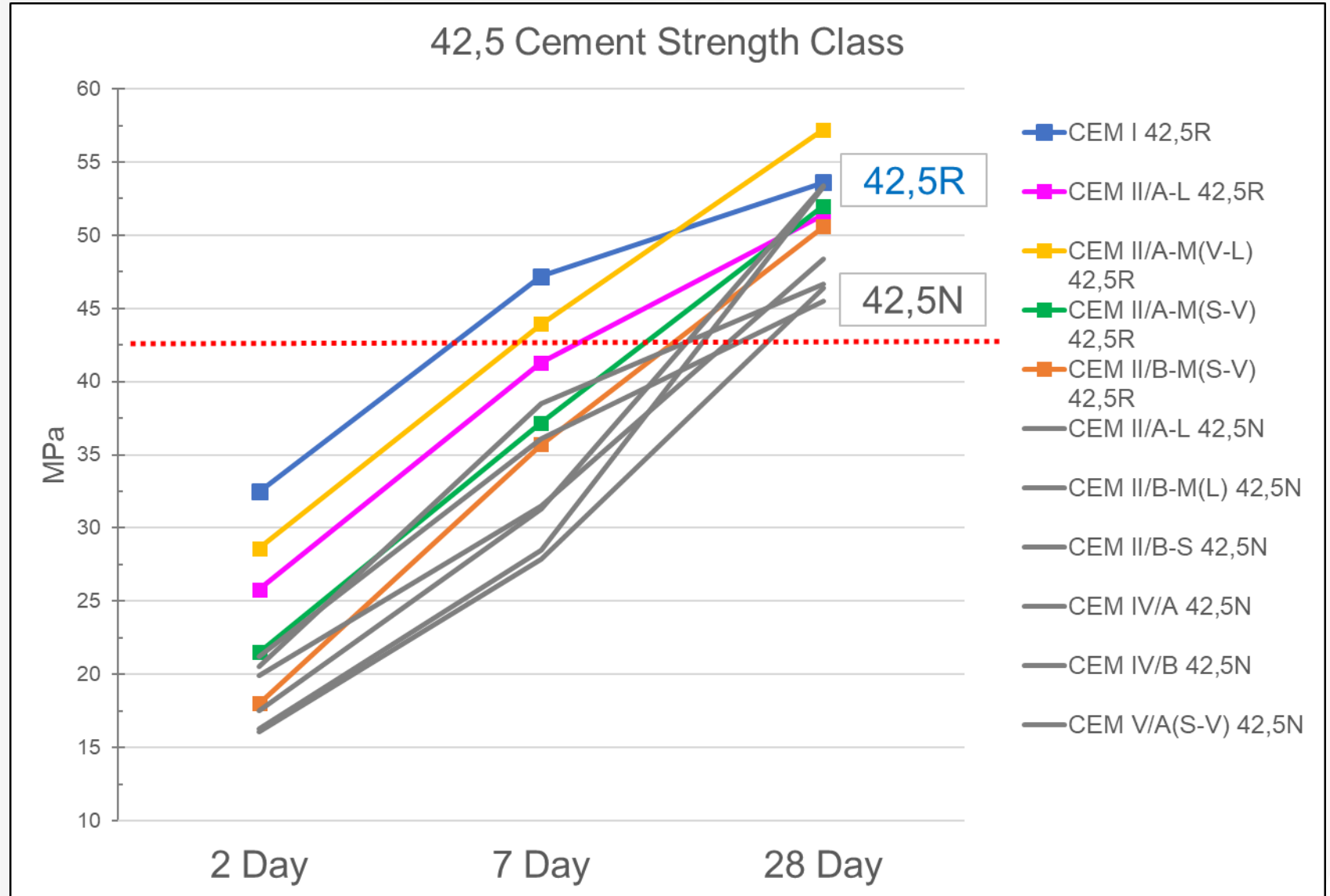

# ➤ Excellent References

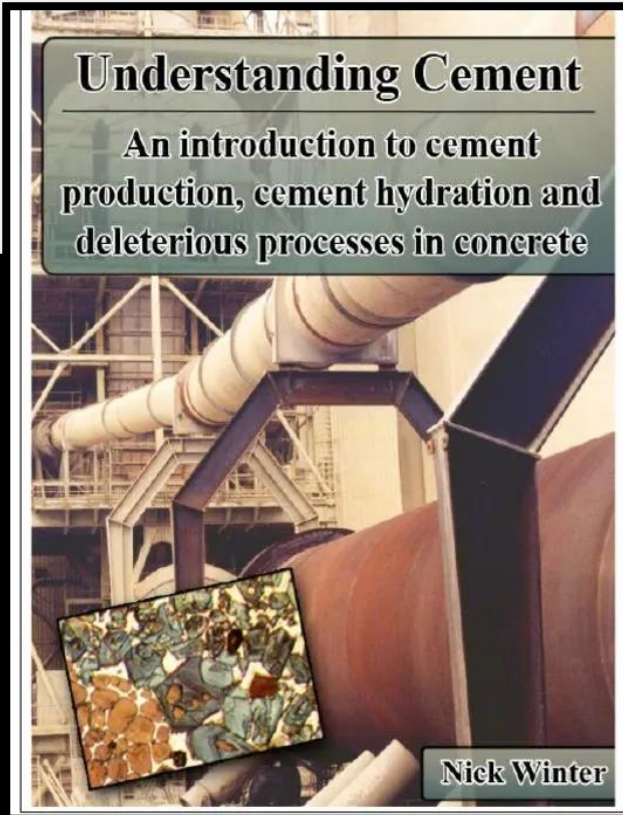
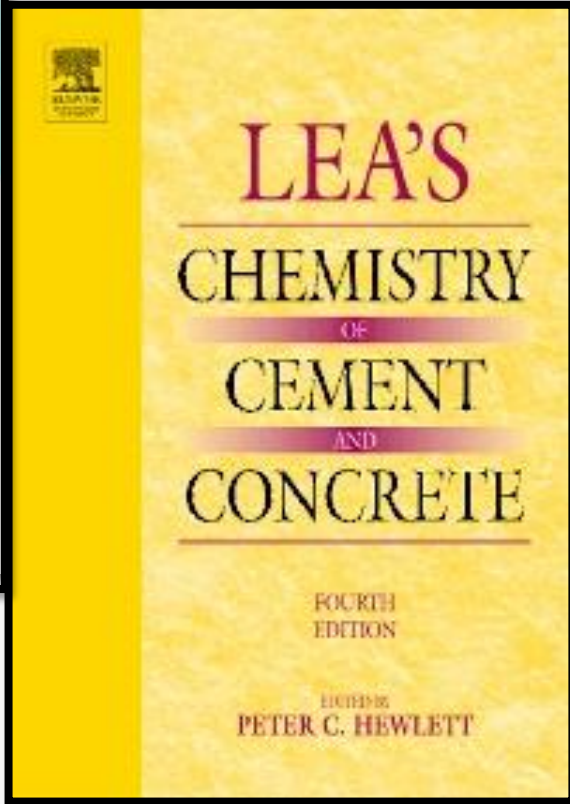
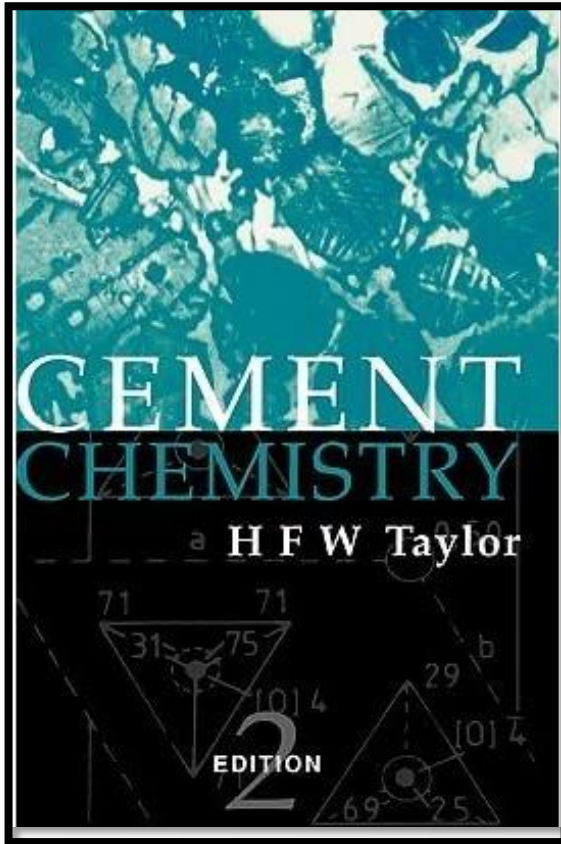



# Thank You!



Dr. Grizelda du Toit



[Grizelda.dutoit@za.afrisam.com](mailto:Grizelda.dutoit@za.afrisam.com)



+27 011 758 6000



# **SANS 50197-5**

VC 9085



# SANS 50197-5 Portland Composite Cements

## SANS 50197-1 Portland Composite Cement

Main types	Notation of the 27 products (types of common cement)		Composition (percentage by mass <sup>a</sup> )										Minor additional constituents
			Main constituents										
			Clinker	Blast-furnace slag	Silica fume	Pozzolana		Fly ash		Burnt shale	Limestone		
						natural	natural calcined	siliceous	calcareous		L	LL	
K	S	D <sup>b</sup>	P	Q	V	W	T	L	LL				
Portland-composite cement <sup>c</sup>	CEM II/A-M	80-88	12-20									0-5	
	CEM II/B-M	65-79	21-35										

## SANS 50197-5 Portland Composite Cement – CEM II/C-M

CEM II/C-M	50-64	36-50	0-5
------------	-------	-------	-----

<sup>d</sup> The number of main constituents other than clinker is limited to two and these main constituents shall be declared by designation of the cement (for examples, see Clause 6).





# SANS 50197-5 Portland Composite Cements

## SANS 50197-1 Portland Composite Cement

Main types	Notation of the 27 products (types of common cement)		Composition (percentage by mass <sup>a</sup> )									Minor additional constituents	
			Main constituents										
			Clinker	Blast-furnace slag	Silica fume	Pozzolana		Fly ash		Burnt shale	Limestone		
						natural	natural calcined	siliceous	calcareous		L		LL
K	S	D <sup>b</sup>	P	Q	V	W	T	L	LL				
CEM V	Composite cement <sup>c</sup>	CEM V/A	40-64	18-30	–	<----- 18-30 ----->		–	–	–	–	0-5	
		CEM V/B	20-38	31-49	–	<----- 31-49 ----->		–	–	–	–	0-5	





# SANS 50197-5 Portland Composite Cements

## SANS 50197-5 Composite Cement – CEM VI

Main types	Notation of the products (types of cement)		Composition (percentage by mass a)										Minor additional constituents	
			Main constituents									Limestone		
			Clinker	Blast-furnace slag	Silica fume	Pozzolana		Fly ash		Burnt shale				
						natural	natural calcined	siliceous	calcareous					
Type name	Type notation	K	S	D <sup>b</sup>	P	Q	V	W	T	L <sup>c</sup>	LL <sup>c</sup>			
CEM VI	Composite cement	CEM VI (S-P)	35-49	31-59	-	6-20	-	-	-	-	-	-	0-5	
		CEM VI (S-V)	35-49	31-59	-	-	-	6-20	-	-	-	-	0-5	
		CEM VI (S-L)	35-49	31-59	-	-	-	-	-	-	6-20	-	0-5	
		CEM VI (S-LL)	35-49	31-59	-	-	-	-	-	-	-	6-20	0-5	

